

# DESIGN NOTES

## Micropower 600kHz Step-Up DC/DC Converter Delivers 5V at 1A from a Li-Ion Cell – Design Note 179

Steve Pietkiewicz

Linear Technology introduces a new micropower DC/DC converter designed to provide high output power from a single cell or higher input voltage. The LT<sup>®</sup>1308 features an onboard switch capable of handling 2A with a voltage drop of 300mV and operates from an input voltage as low as 1V. The LT1308 features Burst Mode™ operation at light load; efficiency is 75% or better for load currents of 1mA. The device switches at 600kHz; this high frequency keeps associated power components small and flat; additionally, troublesome interference problems in the sensitive 455kHz IF band are avoided. The LT1308 is intended for generating power on the order of 2W to 5W. This is sufficient for RF power amplifiers in GSM terminals or for digital-camera power supplies. The LT1308 is available in the 8-lead SO package.

### Single Li-Ion Cell to 5V/1A DC/DC Converter for GSM

GSM terminals have emerged as a worldwide standard. A common requirement for these products is an efficient, compact, step-up converter that develops 5V from a single Li-Ion cell to power the RF amplifier. The LT1308 performs this function with a minimum of external components. The

circuit is detailed in Figure 1. Many designs use a large aluminum electrolytic capacitor (1000 $\mu$ F to 3300 $\mu$ F) at the DC/DC converter output to sustain the output voltage during the transmit time slice, since the amplifier can require more than 1A. The output capacitor, along with the LT1308 compensation network, serves to smooth out the input current demanded from the Li-Ion cell. Efficiency, which reaches 90%, is shown in Figure 2. Transient response of a 0A to 1A load step with typical GSM profiling

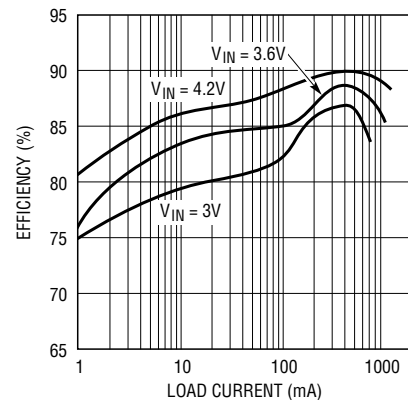

DN179 F02

Figure 2. Efficiency of Figure 1's Circuit Reaches 90%

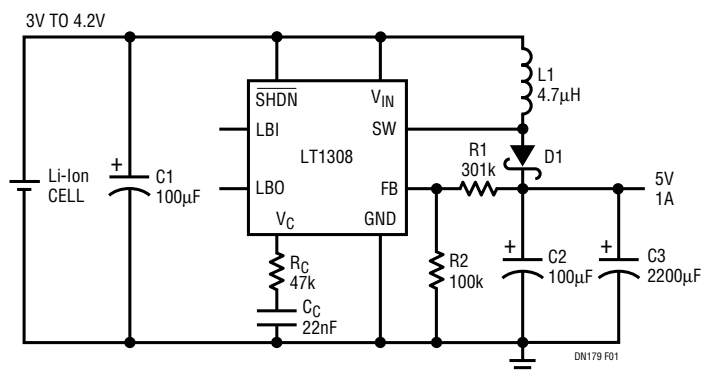

DN179 F01

C1, C2: AVX TPSD107M010R0100  
D1: INTERNATIONAL RECTIFIER 10BQ015  
L1: COILTRONICS CTX5-1  
COILCRAFT D03316-472

Figure 1. Single Li-Ion Cell to 5V/1A DC/DC Converter

(1:8 duty cycle, 577 $\mu$ s pulse duration) is depicted in Figure 3. Voltage droop (top trace) is 200mV. Inductor current (bottom trace) increases to 1.7A peak; the input capacitor supplies some of this current, with the remainder drawn from the Li-Ion cell.

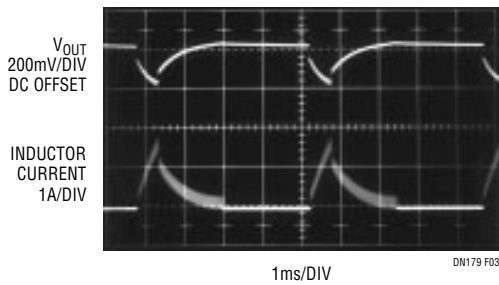
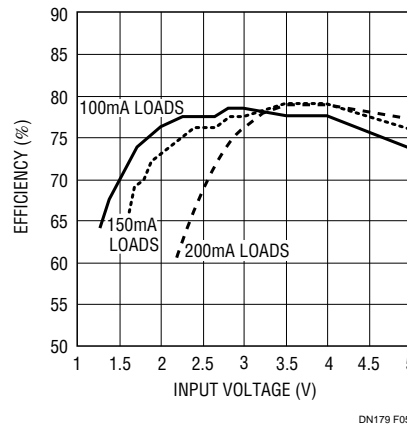

**Figure 3. Transient Response of DC/DC Converter:**  
 $V_{IN} = 3V$ , 0A to 1A Load Step

### 2-Cell Digital-Camera Supply Produces 3.3V, 5V, 18V and -10V

Power supplies for digital cameras must be small and efficient while generating several voltages. The DSP and logic need 3.3V, the ADC and LCD display need 5V and biasing for the CCD element requires 18V and -10V. The power supplies must also be free of low frequency noise, so that post filtering can be done easily. The obvious approach, to use a separate DC/DC converter IC for each output voltage, is not cost effective. A single LT1308, along with an inexpensive transformer, generates 3.3V/200mA, 5V/200mA, 18V/10mA and -10V/10mA from

a pair of AA or AAA cells. Figure 4 shows the circuit. A coupled-flyback scheme is used, actually an extension of the SEPIC (single ended primary inductance converter) topology. The addition of capacitor C6 clamps the SW pin, eliminating a snubber network. Both the 3.3V and 5V outputs are fed back to the LT1308 FB pin, a technique known as split feedback. This compromise results in better overall line and load regulation. The 5V output has more influence than the 3.3V output, as can be seen from the relative values of R2 and R3. Transformer T1 is available from Coiltronics, Inc. (561-241-7876). Efficiency vs input voltage for several load currents on both 3.3V and 5V outputs is pictured in Figure 5. The CCD bias voltages are loaded with 10mA in all cases.



**Figure 5. Efficiency vs Input Voltage for 100mA, 150mA and 200mA Loads on 3.3V and 5V Outputs**

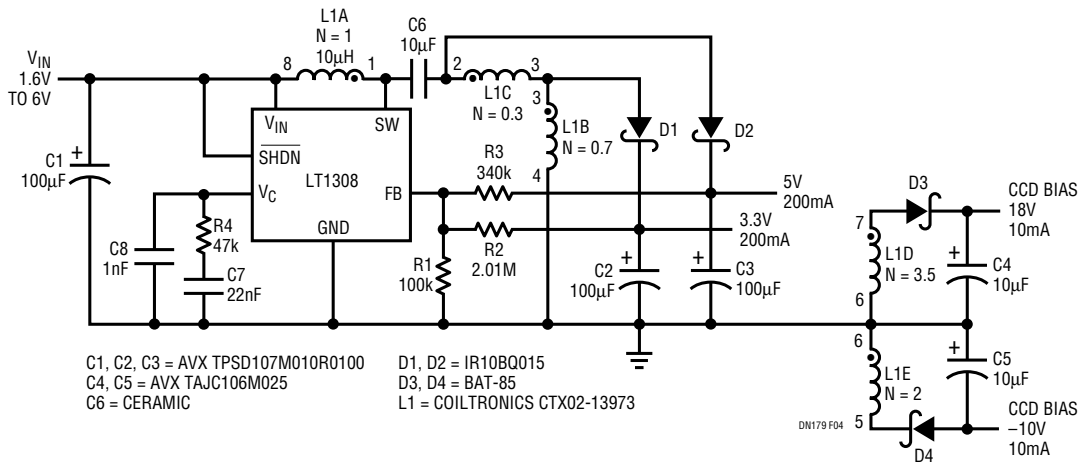

**Figure 4. This Digital-Camera Power Supply Delivers 5V/200mA, 3.3V/200mA, 18V/10mA and -10V/10mA from Two AA Cells**

For literature on our DC/DC Converters, call **1-800-4-LINEAR**. For applications help, call (408) 432-1900, Ext. 2456